

DM45 Machine Accessories



- BT30 Tool Holding Package***
- 1/8", 3/16", 1/4", 5/16", 3/8", 1/2"
 - Solid End Mill Holders
 - Production balanced to 10,000RPM



- High Speed Spindle**
- 25,000RPM
 - 0.76 HP @ 90 psi
 - Perfect for cutting aluminum, plastic, wood, graphite, and other soft materials
 - Fits up to a 1/4" tool



- Mist Coolant Package**
- Runs on standard shop air supply
 - 1 Gal. Stainless Steel reservoir
 - Magnetic nozzle positioner
 - Perfect for extended tool life and better surface finishes



- 12" x 12" Vacu-Vise Table**
- Holds thin, flat or irregular parts
 - Eliminates the need for specialized fixtures
 - Runs on standard shop air supply
 - Works even under flood coolant conditions

* End mills not included



PO Box 9012
 Milesburg, PA 16853
 Tel. 814-360-0279
 Fax 413-793-4886

Dealer

REV 051012 © Copywrite 2005, AjaxCNC is a registered trademark

DM45 TOOLROOM CNC BED MILL



PO Box 9012, Milesburg, PA 16853, 814-360-0279 www.AjaxCNC.com

Mechanical Specifications		
Work Table		
X	31.5"	(800mm)
Y	9.5"	(240mm)
Travels		
X	18"	(457mm)
Y	9"	(228mm)
Z	13"	(330mm)
Quill	4.75"	(120mm)
Spindle Nose to Table		
	3.5" - 16.5"	(89 - 420mm)
Spindle Motor		
	1.5HP	(1.12kW)
Spindle Taper		
	BT30	(ISO30)
Feedrates		
Rapid	up to 425ipm	(10.8m/min)
Cutting	up to 375ipm	(9.53m/min)
Accuracy		
Positioning	+/- 0.001"/12"	(0.025mm/300mm)
Repeatability	+/- 0.0005"	(0.012mm)
Power Requirement		
Spindle	208-240V	1,3-phase
Control	120V 60Hz / 220v	50Hz
Weight		
	1750lbs.	(795Kgs.)
Footprint		
	80" x 53"	(2032mm x 1346mm)

- DM45 Standard Features**
- Rigid Meehanite Cast Iron Construction
 - Precision Rolled Ballscrews
 - ABEC 7 Bearings
 - Hardened & Ground Ways w/ Turcite B
 - Integrated Lube to all Ways & Ballscrews
 - Single or Three-Phase Power
 - Handwheels for Manual Operation w/ DRO
 - Halogen Work Light
 - 3000 RPM Inverter-duty Programmable Spindle
 - Removable Base for Benchtop Operation

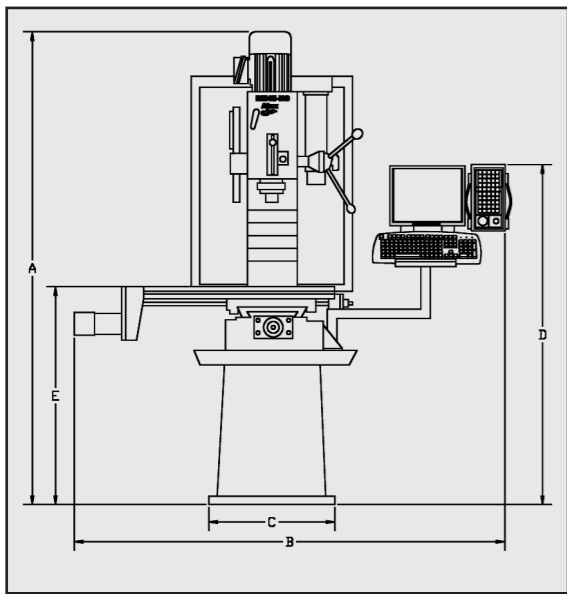

- Machine Control Pendant***
- Jog Buttons for X, Y, Z, 4th
 - Coolant Control
 - Emergency Stop
 - Feedrate Override
 - Spindle Control w/ speed override
 - Cycle Start / Cancel
 - Jog Increment (X1, X10, X100)
 - Programmable Auxiliary Buttons (9)

Easily machine complex parts:

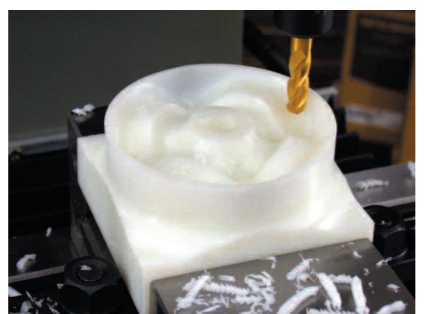
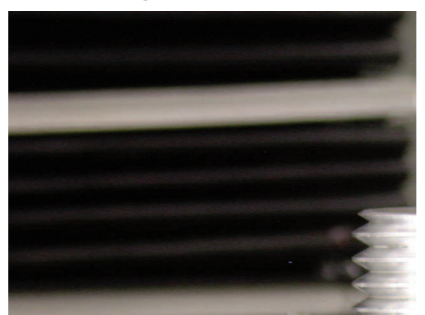
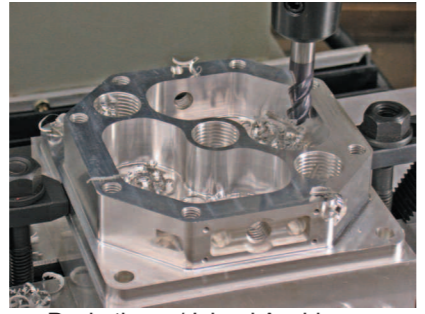

A. Max Height	=	81"	(2058mm)
B. Max Width	=	80"	(2032mm)
C. Base Width	=	20.5"	(520mm)
D. Console Height	=	54"	(1372mm)
E. Table Height	=	38"	(966mm)

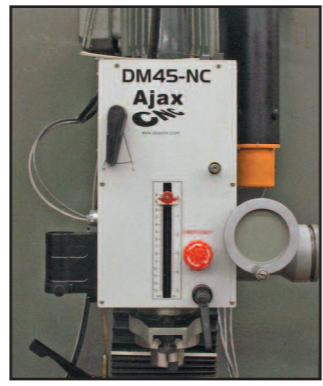

- Rigid Box Head Design**
- Square dove-tail column
 - BT30 taper spindle
 - Manual Quill
 - Hi/Low gear range
 - +/- 90° tilting head
 - 220V 1 or 3-phase
 - Programmable speeds
 - Emergency stop switch

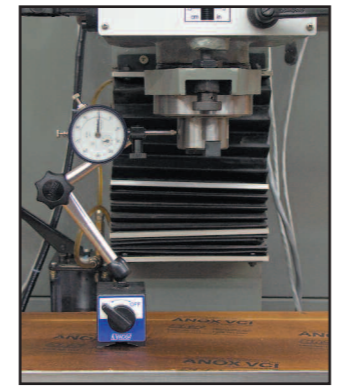

- AjaxCNC = Quality Control**
- Each machine goes through final assembly here in the US and has to meet our exact standards for:
- Backlash
 - Squareness
 - Runout (TIR)
 - Drag



\$13,999

* Optional feature
Prices & specifications subject to change without notice
Machine shown with optional equipment
Warranty: 1 year, parts & technical support

- AjaxCNC Standard Features**
- Autotuning Digital DC Servo Drives
 - 15" LCD Monitor
 - Industrial PC w/ Solid State Hard Drive
 - CNC Linux Control Software
 - USB Port
 - Ethernet Connection
 - Fiber Optic Noise Prevention
 - Conversational & G-code Programming
 - Extensive Canned Cycles
 - 3D Contouring w/ Look-ahead
 - 2D/3D Part Program Graphics
 - Graphical Tool & Part Setups
 - Graphical Help Menus
 - Cutter Compensation
 - Background Editing
 - Teach Mode
 - Standard or Metric Units

